



Worthouse.[®]

Metal Roofing Manufacturing

Roofing Gutters Soffit

MODULAR METAL ROOFING TILES

STEEL GUTTER SYSTEM

PVC SOFFIT

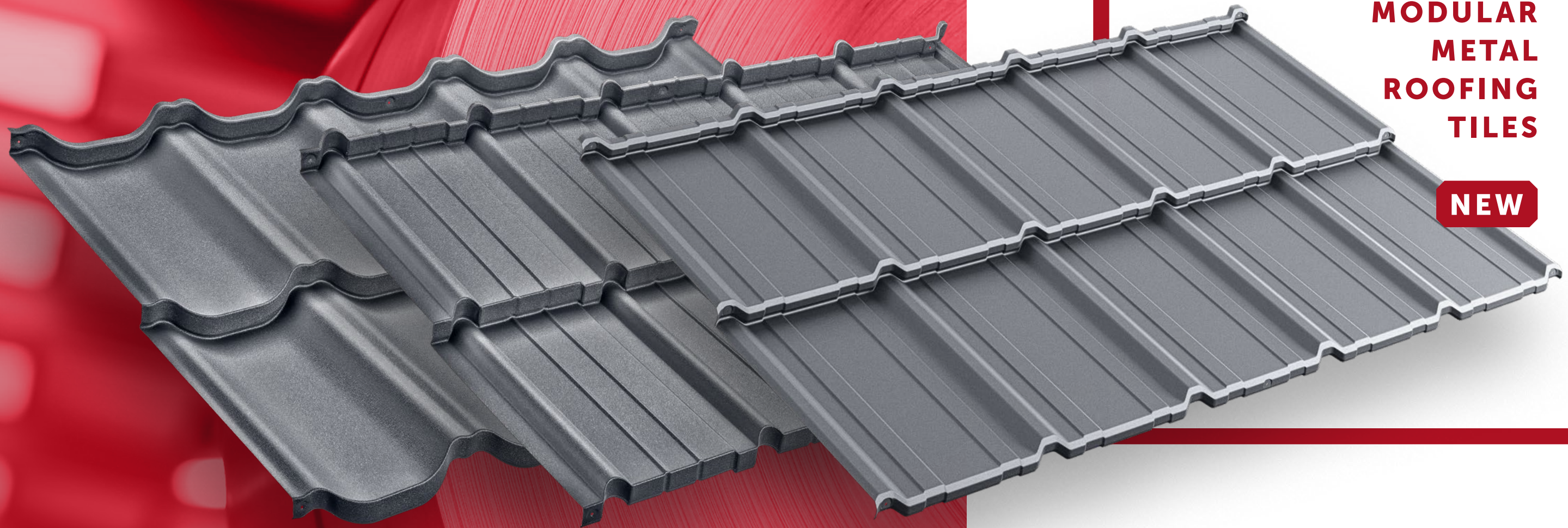

MODULAR METAL ROOFING TILES

NEW

26 GAUGE, G90

Supre, Ulta and Como^{NEW} are made from ArcelorMittal steel – the largest steel producers in the world



Steel is durable

Steel roofing products have nearly twice the lifespan of conventional roofing products



Steel is eco-friendly

Steel can be recycled endlessly, which makes it one of the most environmentally friendly materials



Steel protects

Our steel roofing products have achieved the highest hurricane wind protection, hail impact and fire safety ratings in the US



Extreme weather and impact protection

Against hailstorm, rain, snow, heat and wind

Our products have achieved Class 4 ratings according to the UL 2218 Roof Impact Classifications



Fire protection

We got an "A" in fire protection according to the UL 790 (ASTM E 108) Fire Protection Ratings



High wind protection

We achieved the Class 90 certification for the UL 580 Wind Uplift Resistance test. We have tested our products at wind speeds over 200 mph



The quality of our roofs has been recognized and certified by the Underwriters Laboratories. UL is the largest independent testing laboratory in the world. It is dedicated to promoting safe living and working environments.



SYSTEM WORTHHOUSE METAL MODULAR ROOF
RECOMMENDED BY ITB - BUILDING RESEARCH INSTITUTE
WARSAW - EUROPEAN UNION
RT ITB - 1292/2020 - NUMBER OF TECHNICAL RECOMMENDATION
ITB EU - SECOND BIGGEST BUILDING RESEARCH INSTITUTE IN EUROPE
1486 - NUMBER OF INSTITUTE'S NOTIFICATION IN EUROPEAN UNION



WORTHHOUSE ROOFS PROTECTS YOUR HOME

Class 90



High wind protection

We achieved the Class 90 certification for the UL 580 Wind Uplift Resistance test. We have tested our products at wind speeds over 200 mph.

Class 4



Extreme weather and impact protection

Against hailstorm, rain, snow, heat and wind. Our products have achieved Class 4 ratings according to the UL 2218 Roof Impact Classifications.

Class A



Fire protection

We got an "A" in fire protection according to the UL 790 (ASTM E 108) Fire Protection Ratings.

PROTECTIVE SHIELD

Noble Matt

Covered with the Noble Matt coating, it effectively protects against long-term wear and provides maximum corrosion resistance in any conceivable application.

Stable and constant

The Noble Matt coating not only protects against discoloration, but also functions as an all weather shield.

It says no to re-roofing

Forget about re-roofing. Supre, Ulta and Como will serve you reliably for generations. The steel and protective shield form a really powerful duo of protection.

Manufactured in color

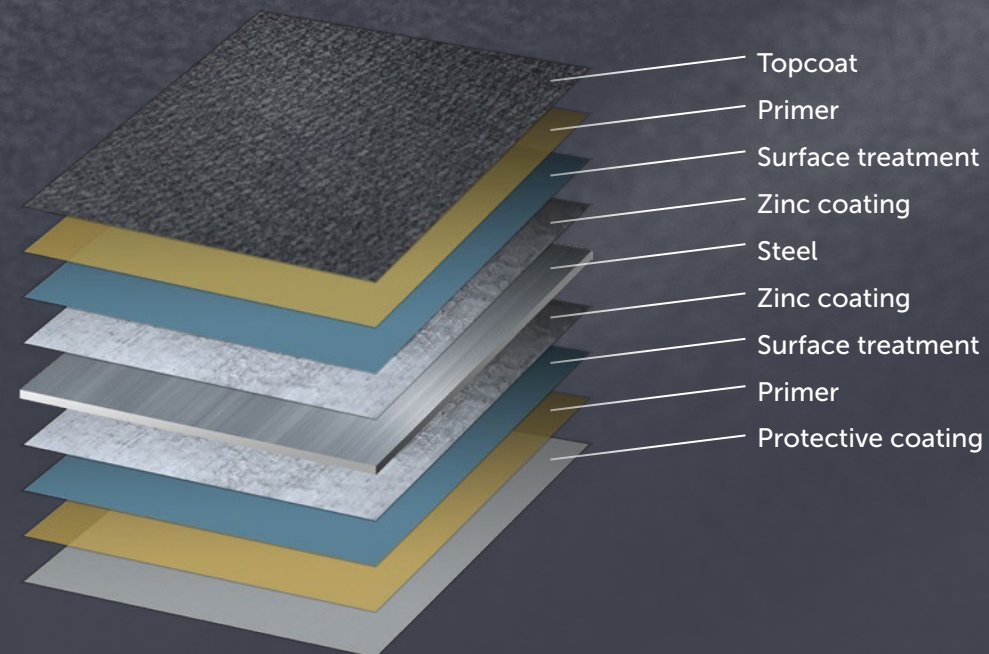

G90
0.90 oz/ft²

ZINC
275 minimum g/m²



PROTECTIVE SHIELD

Magnelis® **NEW**

Magnelis® is a unique metallic coating that represents a breakthrough in corrosion protection. It is the best material with numerous uses.

Magnelis® coating was undergone the most severe corrosion performance tests in Daytona Beach laboratories. The results were incomparable with any other coating on the market!!!

Corrosion performance – outdoor exposure.
Complementary data in very severe environment
First data after 1 year exposure.

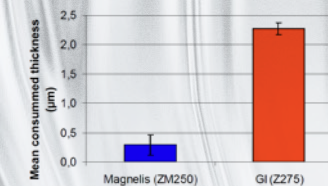

The Magnelis® corrosion performance is a minimum of 3 times better than Galvanized Steel in all environmental classes!

WORTHOUSE IS DELIGHTED TO PRESENT TO YOU OUR ROOF OFFERING OF MAGNELIS COATING WITH AN AMAZING WARRANTY

- **25 Year Warranty for C3/C4 environment**
- **20 Year Coastal Warranty for C5 environment**

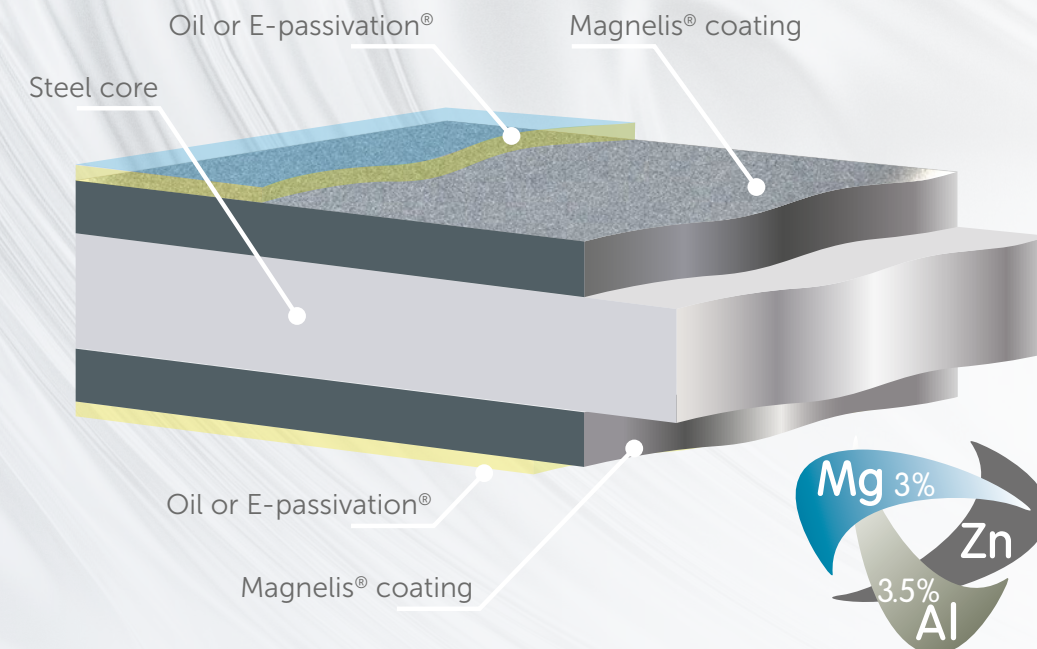



**MODULAR ROOFS
ARE EASY
TO INSTALL**

SUPRE	ULTA	COMO
Weight of one pallet: 2920 lb	Weight of one pallet: 2650 lb	Weight of one pallet: 2980 lb
Quantity per pallet: 350 pcs	Quantity per pallet: 319 pcs	Quantity per pallet: 352 pcs
Effective surface area of one pallet: 3032 sq. ft	Effective surface area of one pallet: 2739 sq. ft	Effective surface area of one pallet: 3133 sq. ft



Simple transport

One pallet contains over 3000 sq. ft (Supre, Como), 2700 sq. ft (Ultra) of material – enough to cover an average size roof



Easy to install

Pre-drilled holes and modular assembly speed up installation and reduce mistakes



Cost effective installation

Our products average less than 5% waste during installation compared to industry norms greater than 10%



Atlantic Gray

Noble Matt

NEW



Atlantic Sand

Noble Matt

NEW



Take to the sky with Raven Black

Ravens are very intelligent birds, which played an integral role in the mythology of the indigenous peoples of the Pacific Northwest, as well as art and literature. For many cultures the bird was a religious symbol. Some even believed that it was God. Raven Black. The color of freedom

Raven Black

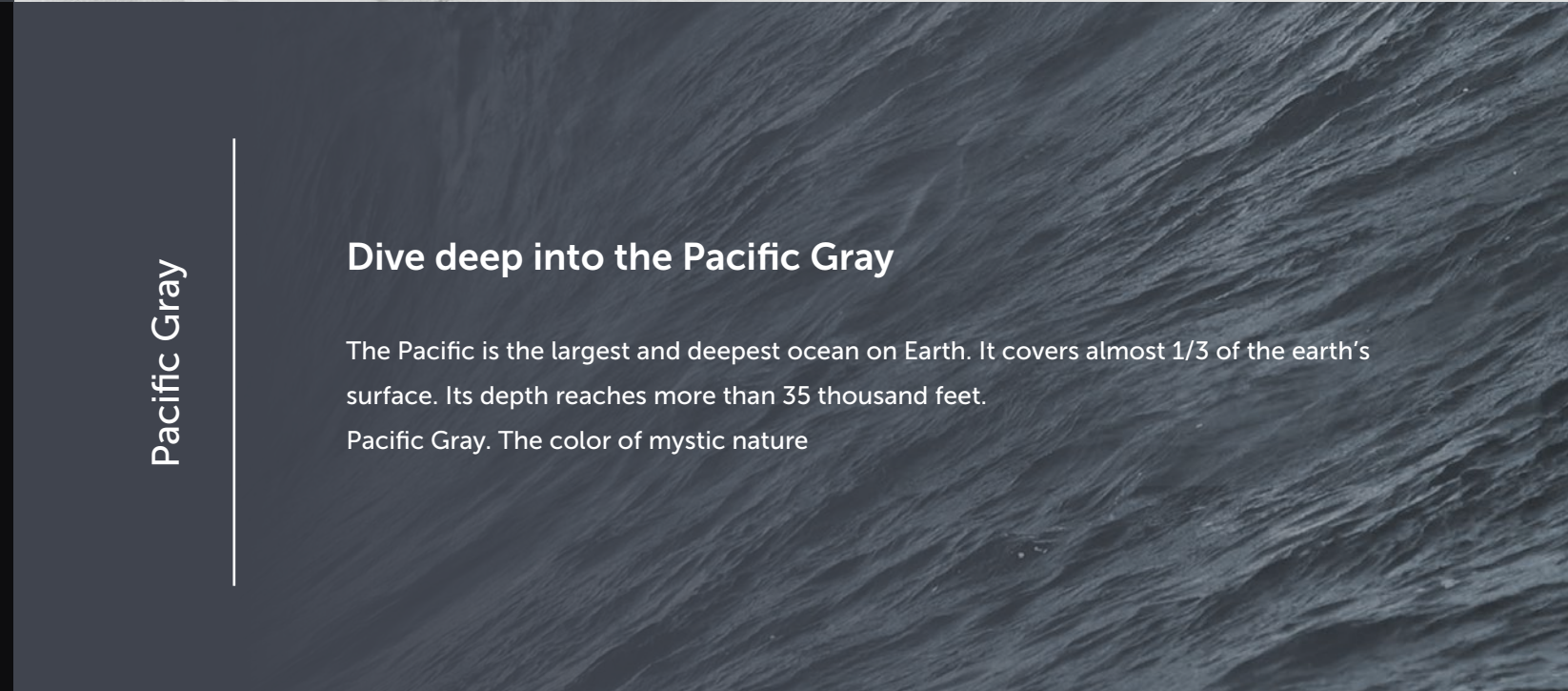

Pacific Gray

Dive deep into the Pacific Gray

The Pacific is the largest and deepest ocean on Earth. It covers almost 1/3 of the earth's surface. Its depth reaches more than 35 thousand feet. Pacific Gray. The color of mystic nature

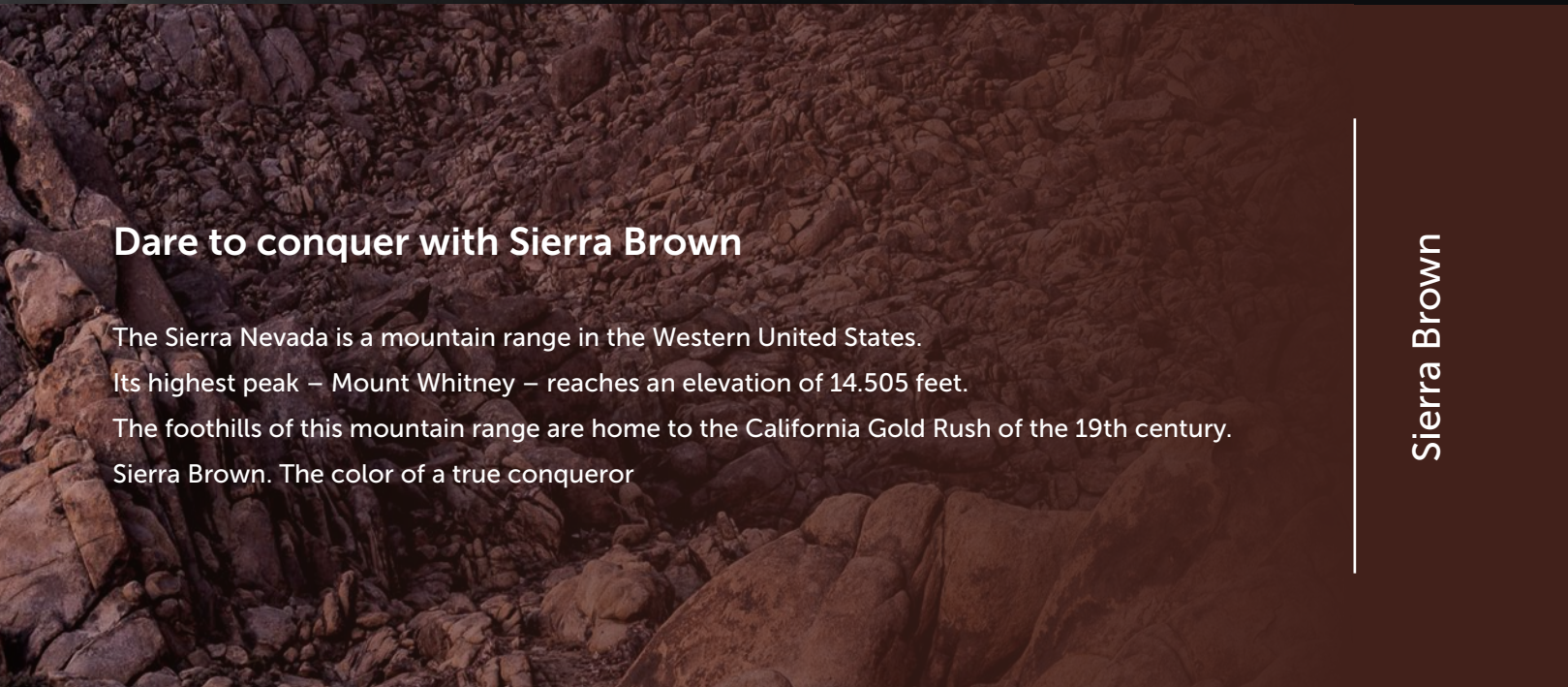

Dare to conquer with Sierra Brown

The Sierra Nevada is a mountain range in the Western United States. Its highest peak – Mount Whitney – reaches an elevation of 14.505 feet. The foothills of this mountain range are home to the California Gold Rush of the 19th century. Sierra Brown. The color of a true conqueror

Sierra Brown

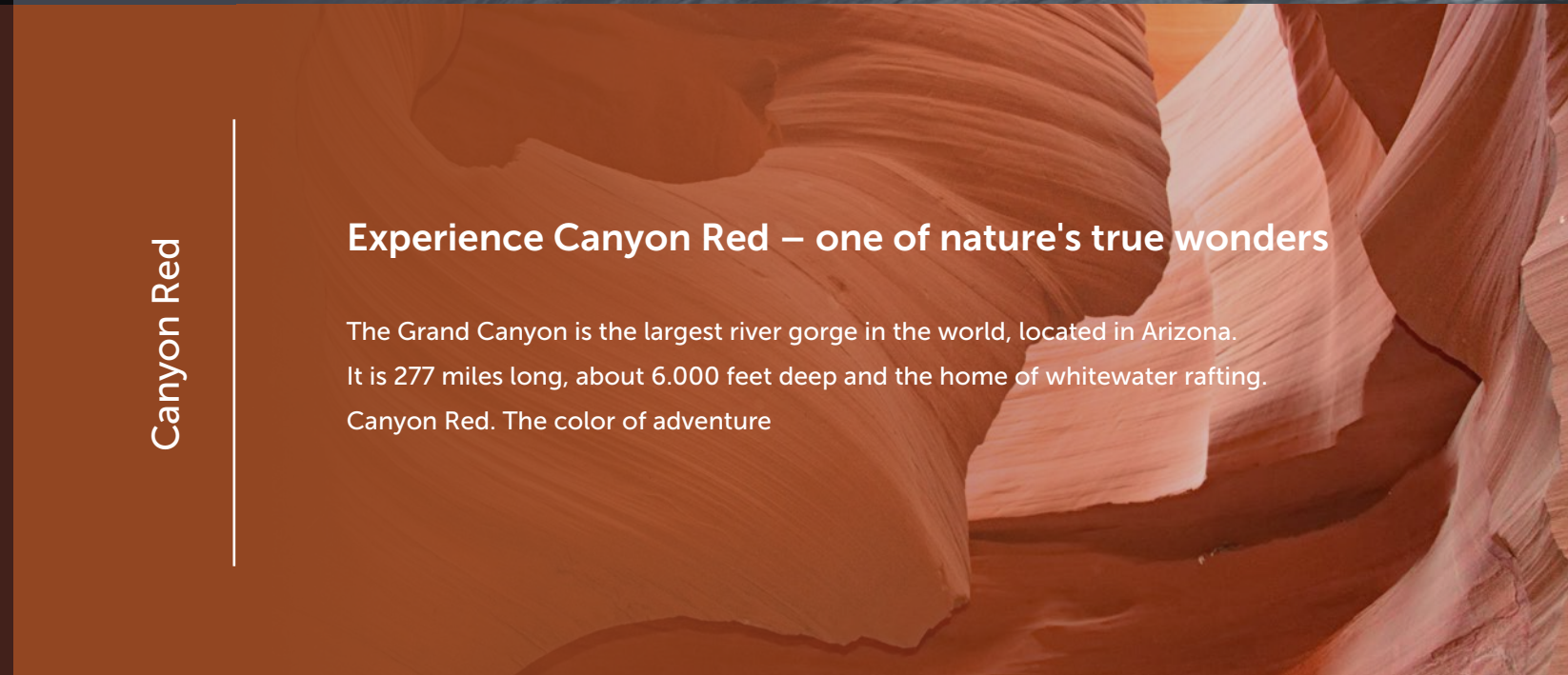

Canyon Red

Experience Canyon Red – one of nature's true wonders

The Grand Canyon is the largest river gorge in the world, located in Arizona. It is 277 miles long, about 6.000 feet deep and the home of whitewater rafting. Canyon Red. The color of adventure

Como ^{NEW} makes your home beautifully protected



INCREASED HURRICANE RESISTANCE



SYMMETRICAL SHAPE

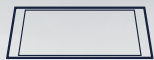

LARGER COVERING AREA
ONLY 11 PANELS PER 1 SQ EFFECTIVE COVER

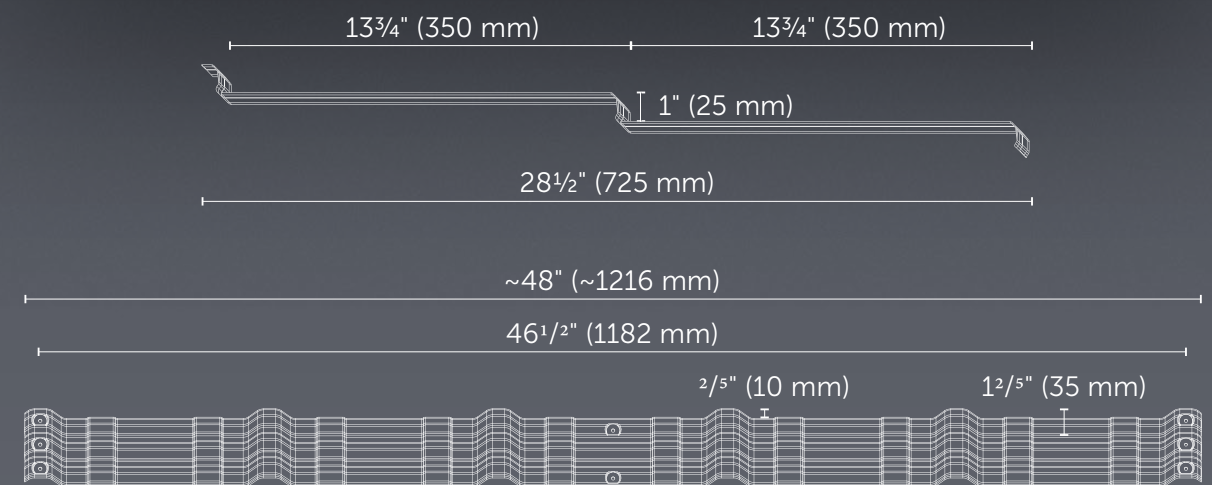
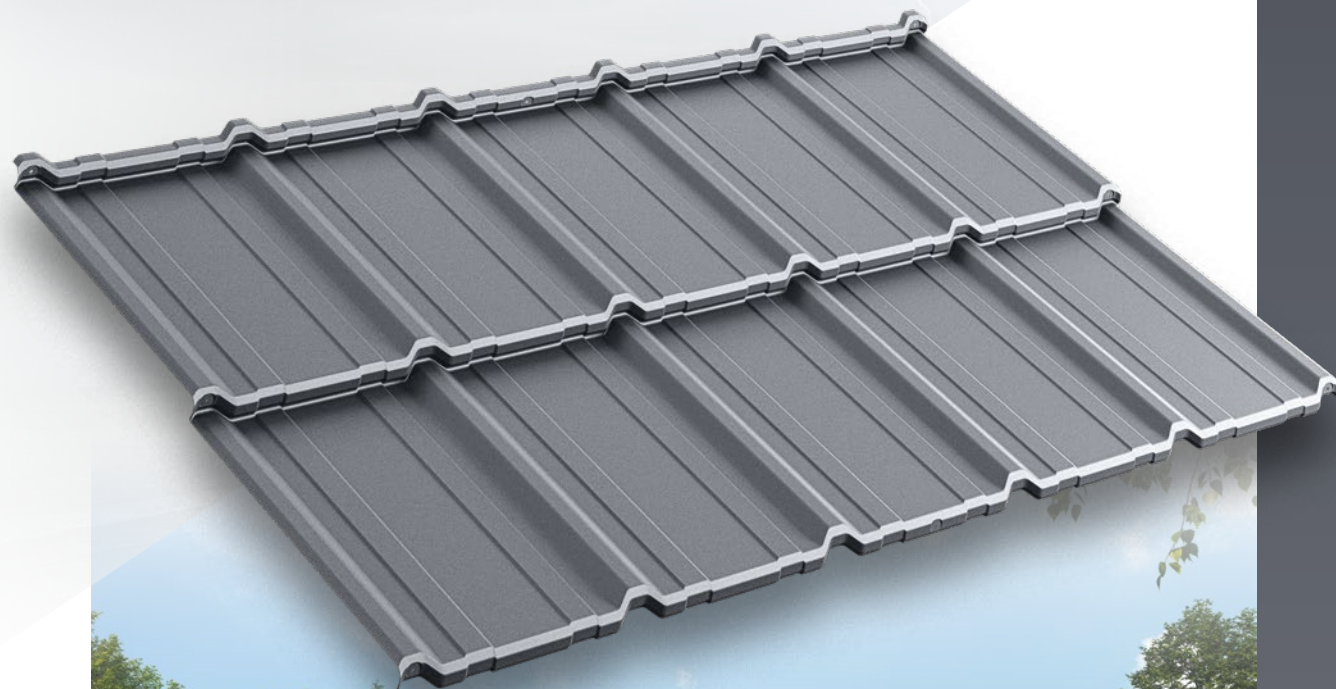

Como

Effective width

3.88 ft

1182 mm

Total width

3.99 ft

1216 mm

Weight per piece

8.16 lb

3.7 kg

Effective surface area of one sheet

8.9 sq. ft

0.827 sq. m

Quantity per pack

352 pcs

Effective surface area of one pack

3133 sq. ft

291.104 sq. m

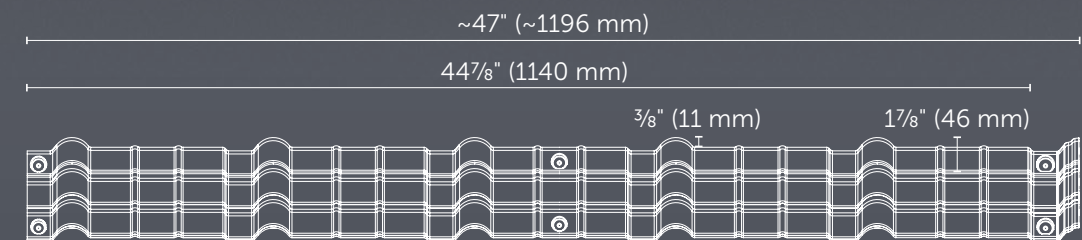
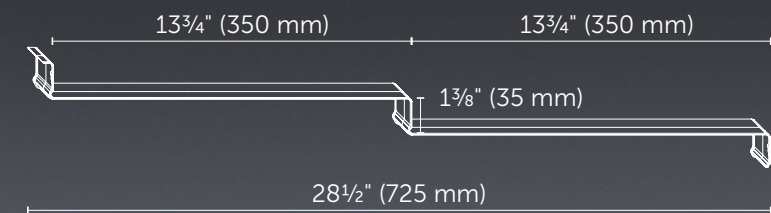
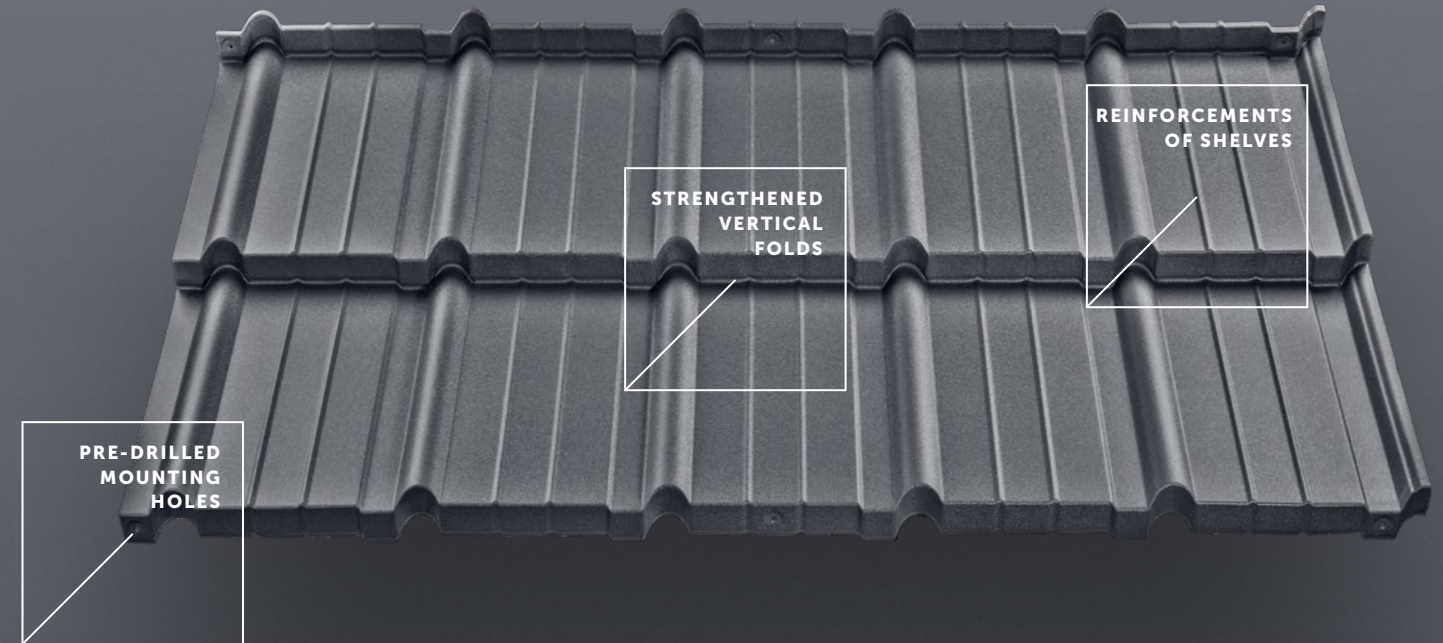
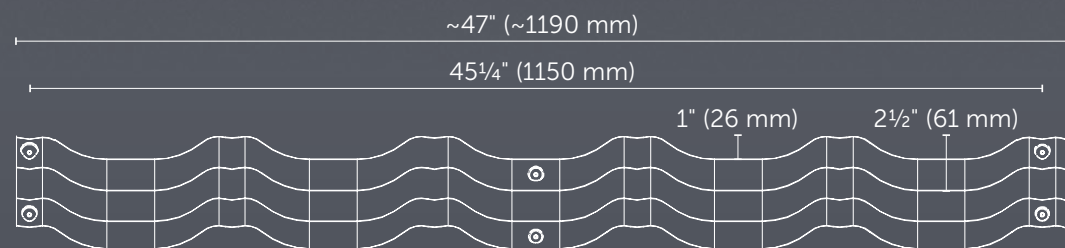
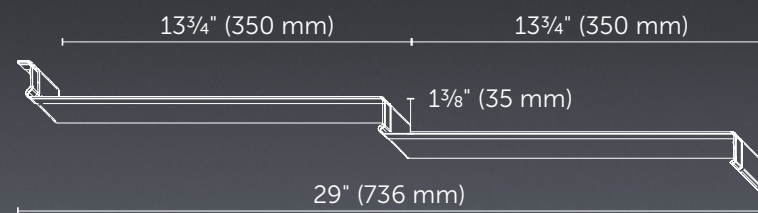
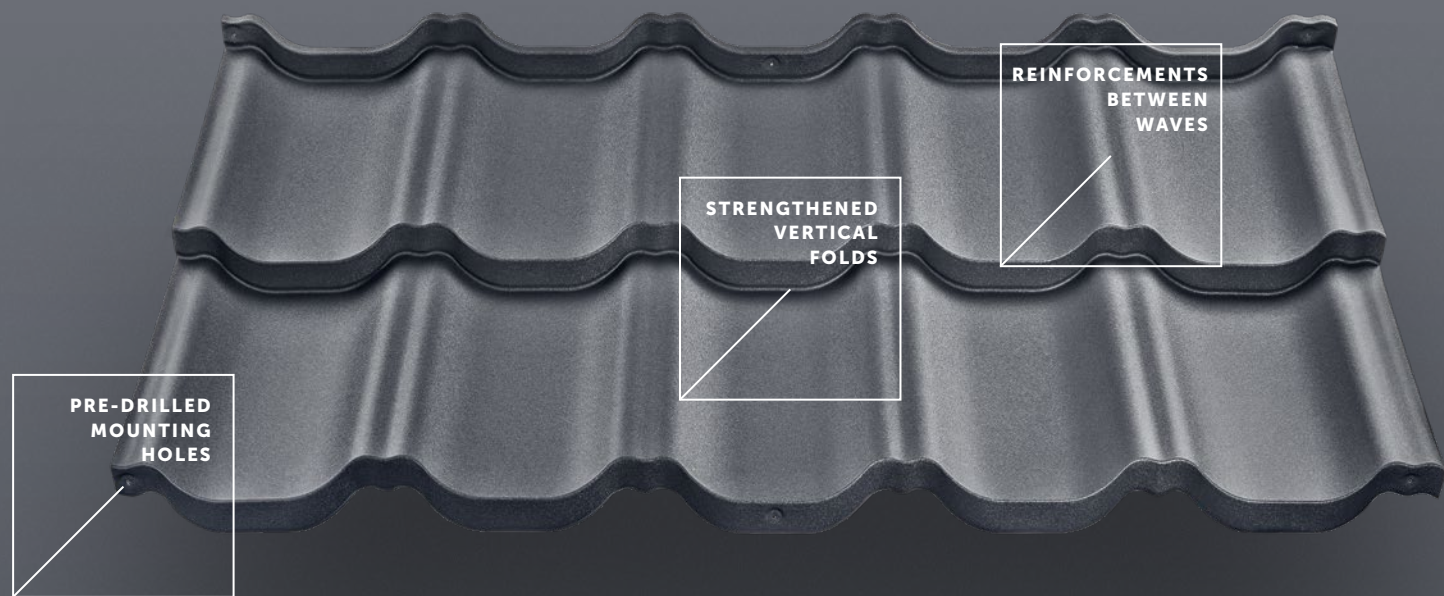

Supre



Effective width	Total width	Weight per piece
3.77 ft 1150 mm	3.9 ft 1190 mm	8.16 lb 3.7 kg

Effective surface area of one sheet	Quantity per pack	Effective surface area of one pack
8.66 sq. ft 0.805 sq. m	350 pcs	3032 sq. ft 281.75 sq. m

Ulta



Effective width	Total width	Weight per piece
3.74 ft 1140 mm	3.92 ft 1196 mm	8.16 lb 3.7 kg

Effective surface area of one sheet	Quantity per pack	Effective surface area of one pack
8.59 sq. ft 0.798 sq. m	319 pcs	2739 sq. ft 254.56 sq. m

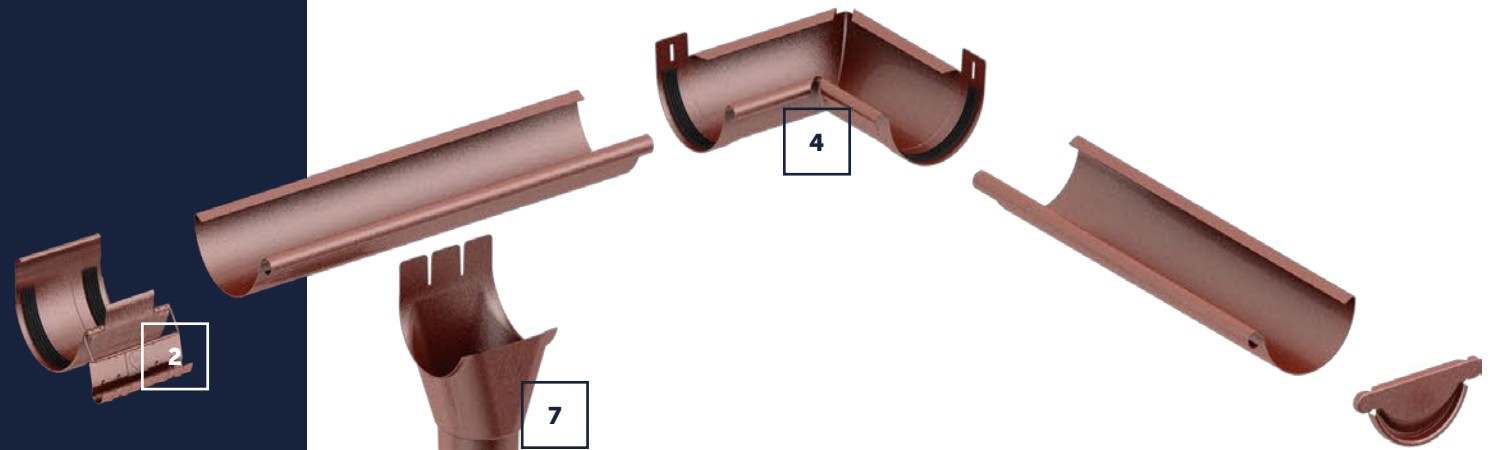

SYSTEM

5³/₄" / 3¹/₂"

COLORS

 **Brown** ~RAL 8028/8017
GreenCoat RWS 434

 **Graphite** ~RAL 7011
GreenCoat RWS 087

 **Black** ~RAL 9005
GreenCoat RWS 015

 **White** ~RAL 9002
GreenCoat RWS 001

 **Brick-red** ~RAL 8004
GreenCoat RWS 742

30
YEAR
WARRANTY

GREENCOAT® RWS
COLORFUL STEEL

SSAB

The colors shown are illustrative and may vary from the actual ones.

GUTTER SYSTEM ELEMENTS

1. Gutter
2. Joint connector
3. Fascia hanger
4. Inside corner
5. Outside corner
6. End cap
7. Drop outlet
8. Elbow
9. Downspout
10. Downspout heavy duty mount
11. Downspout strap anchor
12. Downspout wall bracket
13. Downspout connector
14. Outflow elbow
15. Rain catcher
16. Tee connector
17. Rain trap

**RAIN-THIRSTY
FLAMINGO**



Patent for invention
217565

Patent pending
Rp14731, Rp17669, Rp18757
RWU66816, RWU68626



Excellent tightness

Flamingo elements are moulded in specially designed, patented moulds. Forget about the leaks when assembled



Only the best materials

Flamingo was manufactured from GreenCoat RWS (Rain Water System) steel produced by SSAB – a Swedish global steel company. GreenCoat RWS was developed specifically to create high quality gutter systems

It has a double sided coating and is exceptionally durable. Coatings used in GreenCoat RWS products include polymer grains, which improve the surface scratch resistance



Evenness for years

Flamingo has a 30-year warranty for the C1-C4 environmental class (industrial and coastal areas with a high aggressiveness of the corrosive environment)



Safe transport and storage

Flamingo elements are factory-protected with foil. We transport it in specially designed packaging and care about the highest standard of storage



GUTTER

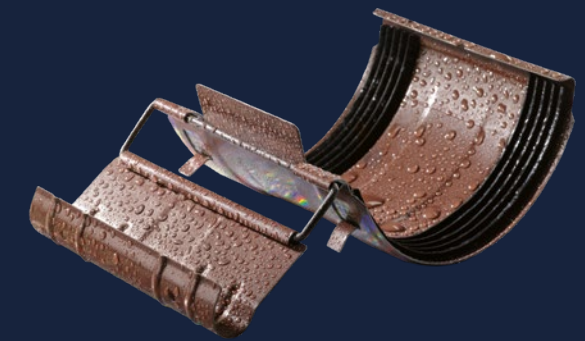

JOINT CONNECTOR



DROP OUTLET

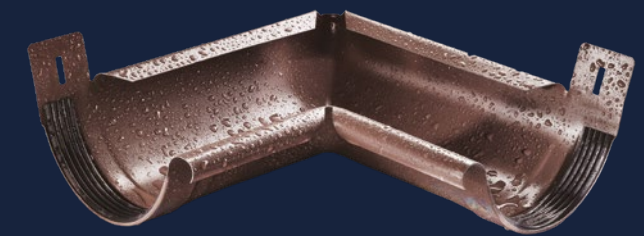

INSIDE CORNER
90°



OUTSIDE CORNER
90°



FASCIA HANGER

END CAP



DOWNSPOUT



DOWNSPOUT
HEAVY DUTY
MOUNT

DOWNSPOUT CONNECTOR



ELBOW

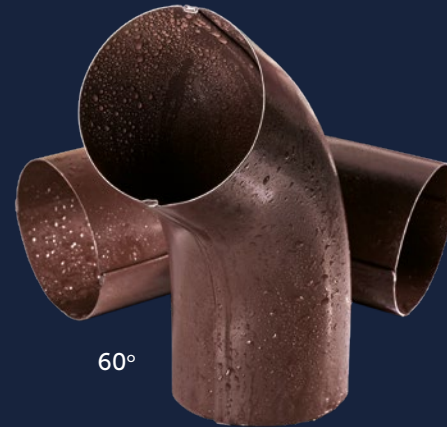

60°

TEE CONNECTOR

RAIN CATCHER



60°

OUTFLOW ELBOW



High resistance to environmental conditions

GreenCoat RWS products are a lightweight construction material with a beautiful shine. They are very resistant to corrosion, UV rays and scratches



Complete steel roof

Flamingo is ideally suited with Worthouse Modular Roofing Tiles



Easy and fast assembly

Flamingo components are made with care for the smallest detail and fit together perfectly, making the assembly fast and easy



Extra strong gutter hangers

Flamingo hanger can easily carry weight of 165 lbs

G90
0.90 oz/ft²
ZINC
275 g/m²
minimum

The system is made of the best quality steel covered with zinc 0.90 oz/ft²



Proven system

It is the best system for metal roofing. Recommended by roofers. Flamingo has been a success for many years



Gold Medal MTP BUDMA 2010
for the Flamingo Steel Gutter System

DIMENSIONS

Covering width

12"

306 mm

Panel height

1/2"

12.2 mm

Panel length

9' 10"

3000 mm

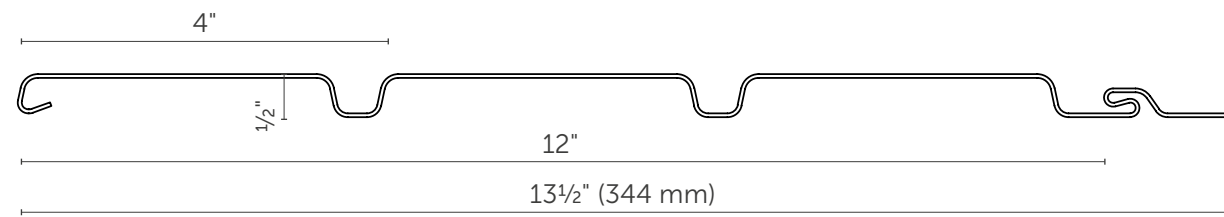

COLORS

Traditional



Brown
~RAL 8017



Black
~RAL 9005

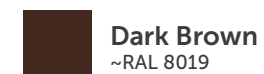

Dark Brown
~RAL 8019



White
~RAL 9010



Graphite
~RAL 7016

Wood grain



Golden Oak
Wood grain



Dark Oak
Wood grain



Winchester Oak
Wood grain

The colors shown are illustrative and may vary from the actual ones.

PVC SOFFIT

STANDARD PANEL

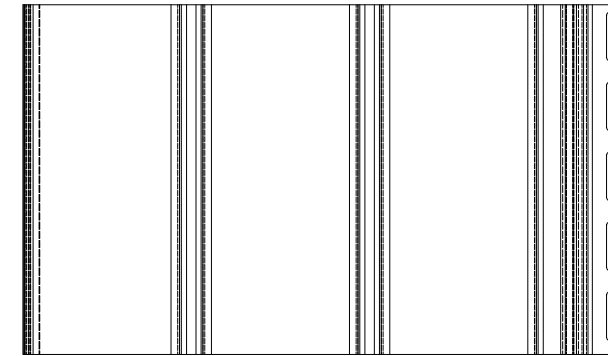

VENTED PANEL

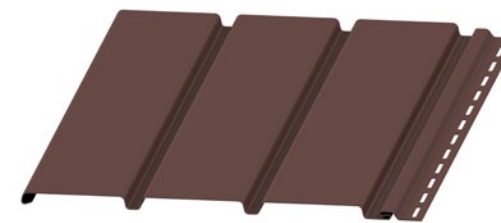
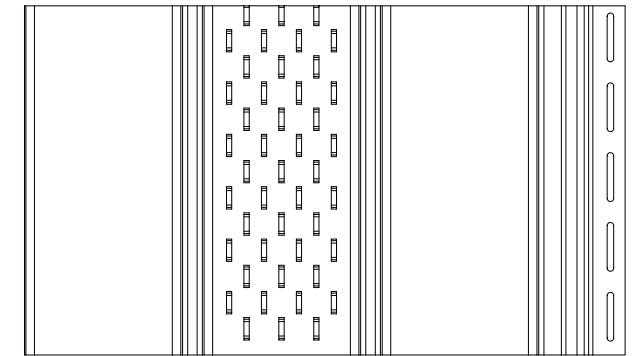

Traditional

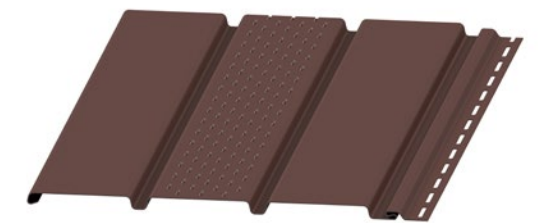

Wood grain



J-channel

Traditional — Wood grain



H-channel

Traditional — Wood grain



Inside corner

Traditional — Wood grain



Outside corner

Traditional — Wood grain

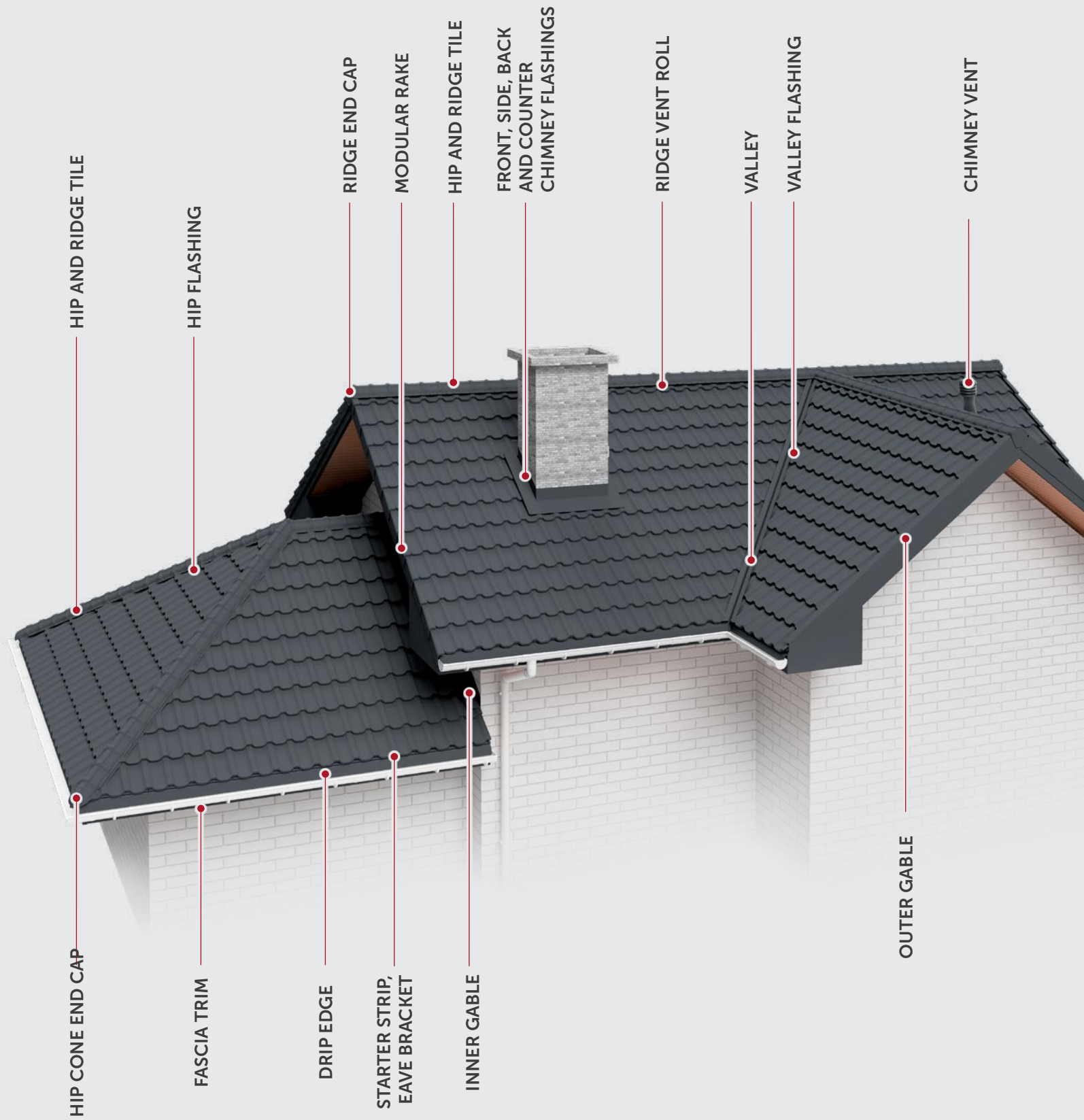

ACCESSORIES

#smartmetalroofing

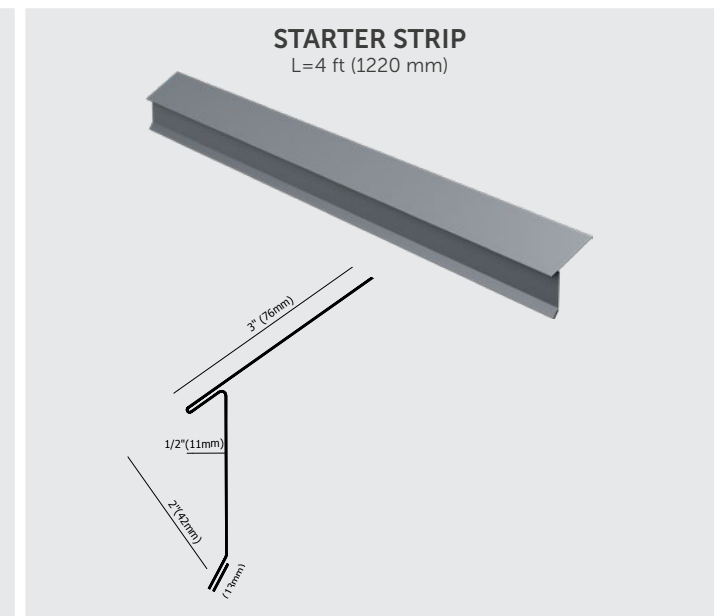
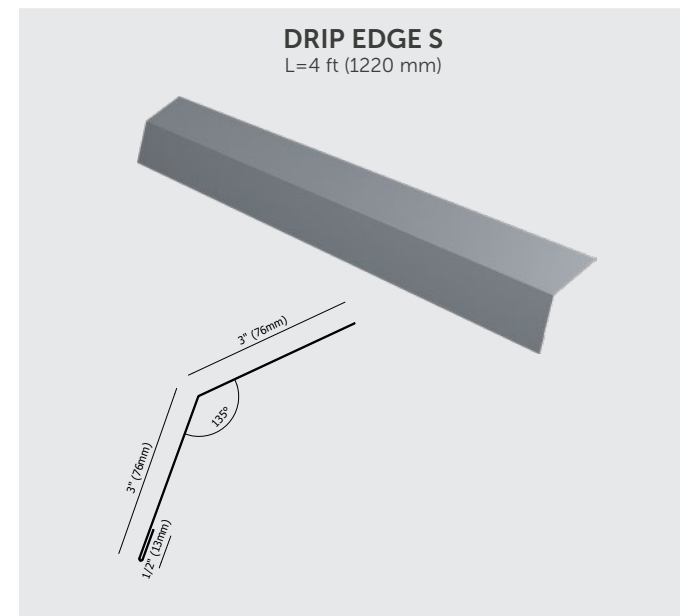
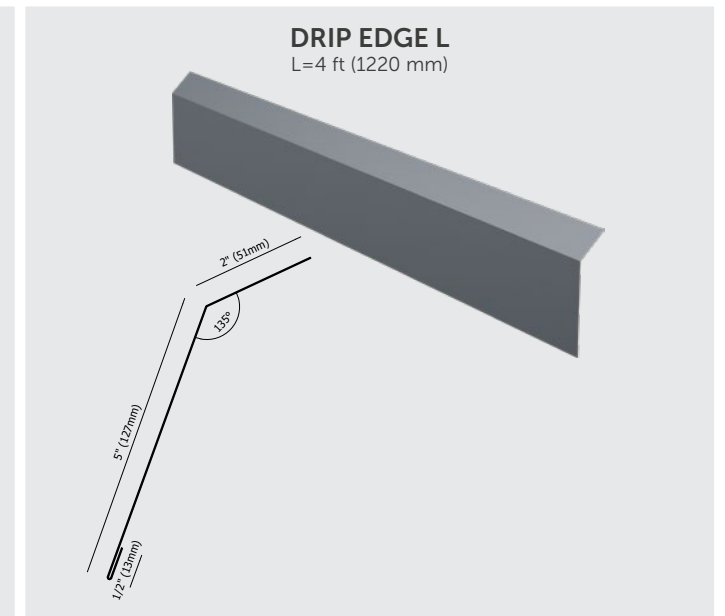
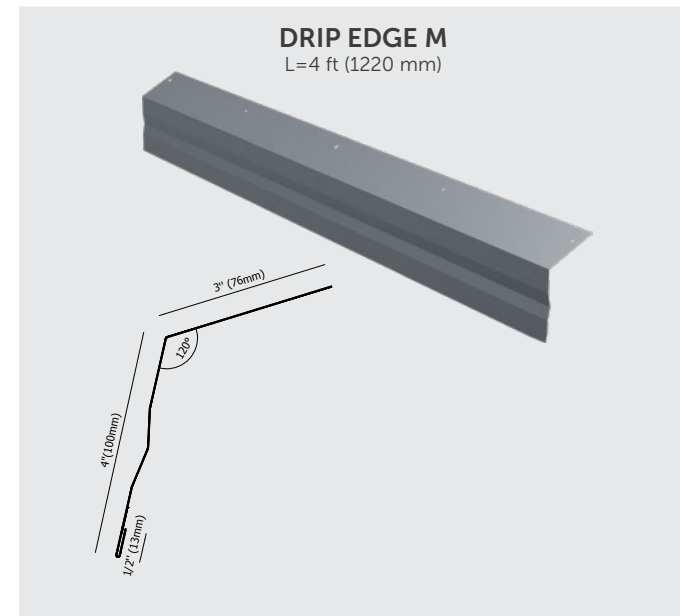
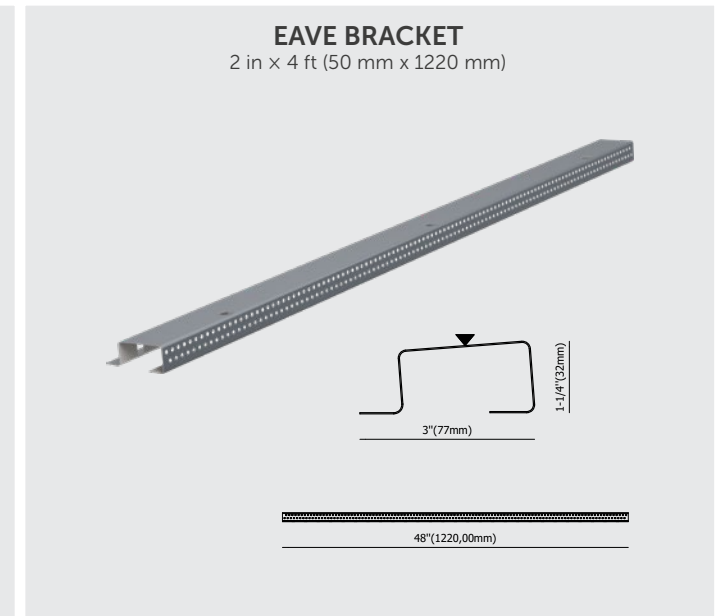
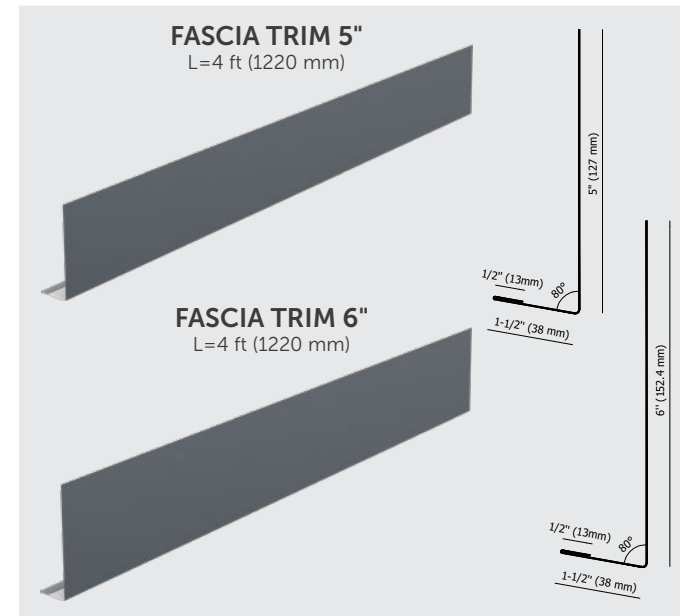

MODULAR RAKE FOR SUPRE

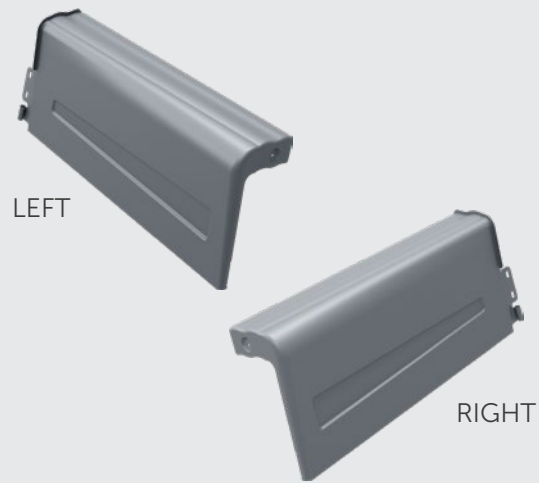

MODULAR RAKE FOR ULTA



VALLEY
L=4 ft (1220 mm)

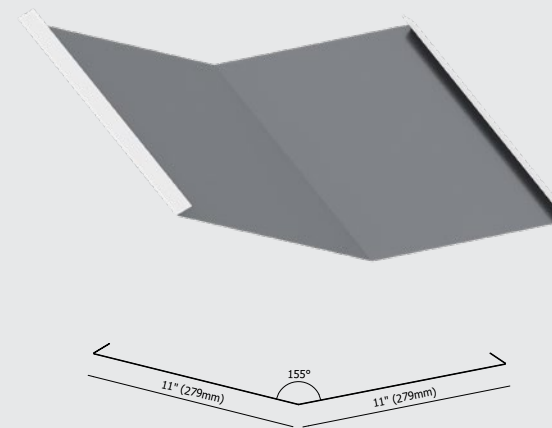

VALLEY FLASHING FOR SUPRE/ULTA
L=4 ft (1220 mm)

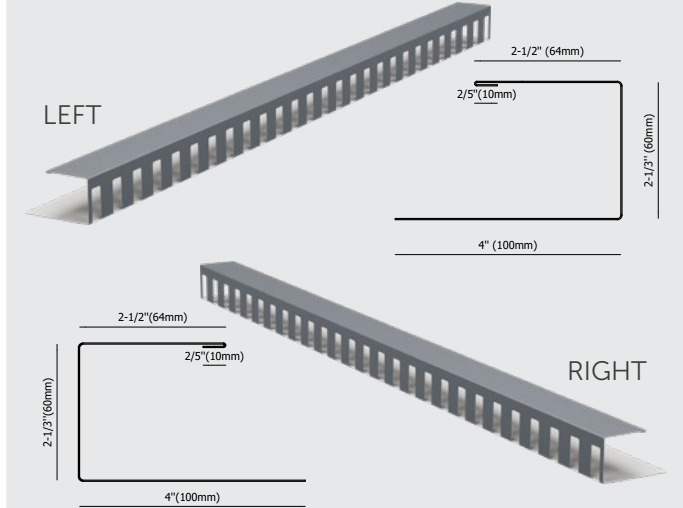

INNER GABLE
L=4 ft (1220 mm)

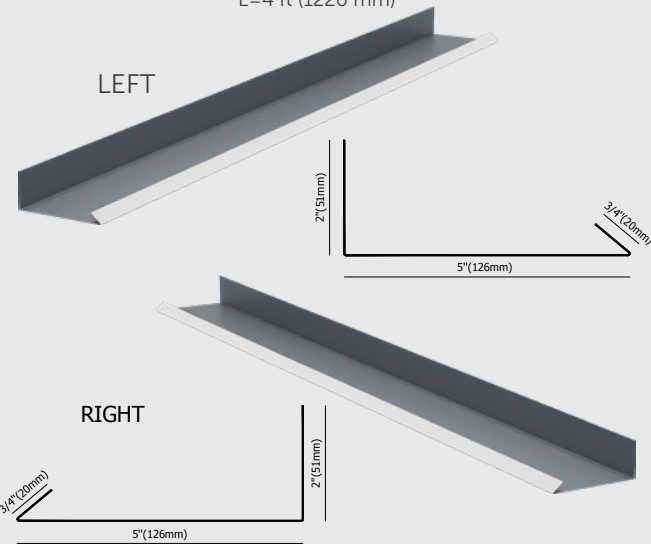

OUTER GABLE 3/4
L=4 ft (1220 mm)

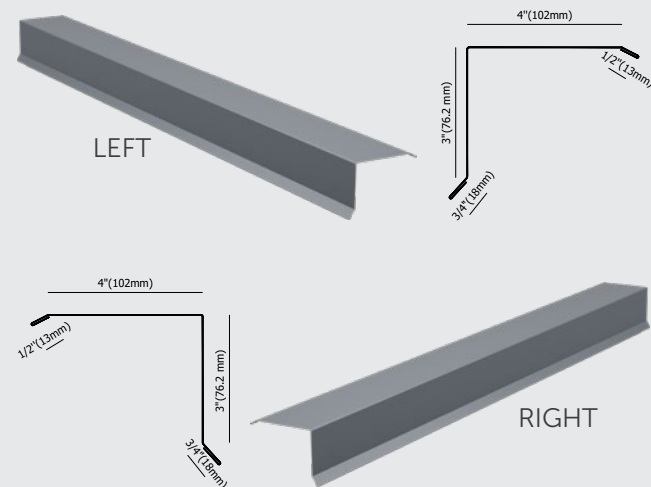

SIDE CHIMNEY FLASHING (OUTER DORMER FLASHING)
L=4 ft (1220 mm)

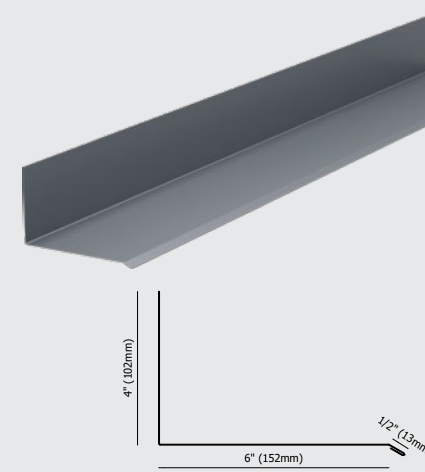

BACK CHIMNEY FLASHING
L=4 ft (1220 mm)

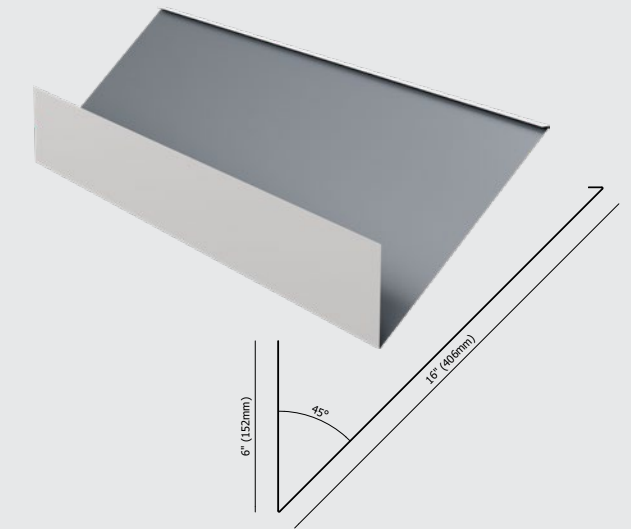

OUTER GABLE 4/4
L=4 ft (1220 mm)

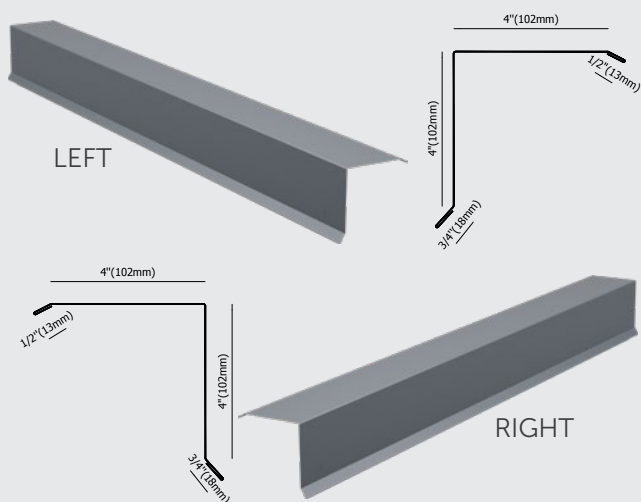

FRONT CHIMNEY FLASHING
L=4 ft (1220 mm)

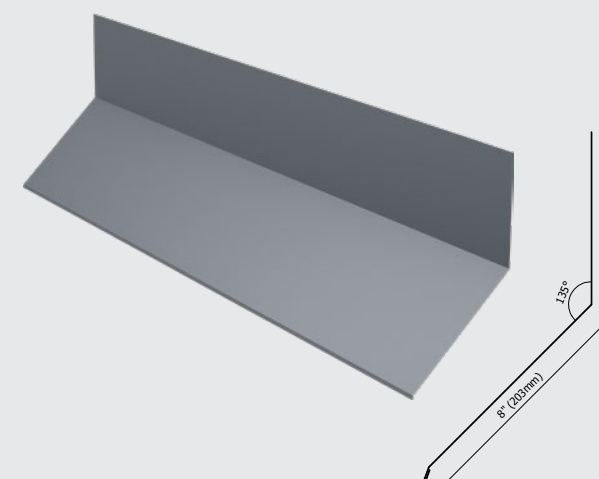

COUNTER FLASHING
L=4 ft (1220 mm)

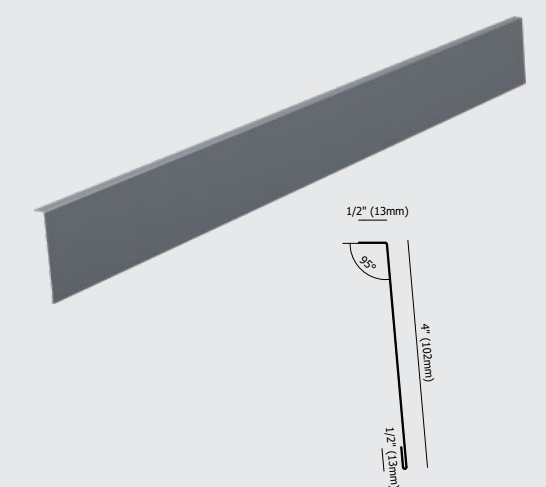

HIP AND RIDGE TILE
L=49" (1250 mm)



RIDGE END CAP
5.35 in x 0.71 in x 3.78 in
(212 mm x 18 mm x 96 mm)



HIP CONE END CAP
12.5 in x 8 in x 3.25 in
(320 mm x 220 mm x 80 mm)



HIP AND RIDGE TILE LUX FOR SUPRE
L=45.08" (1145 mm)

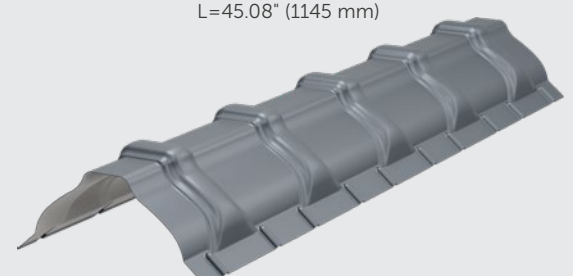

RIDGE END CAP RC-LUX



HIP END CAP RC-LUX

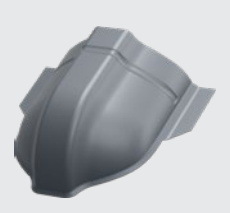

NOBLE MATT COATED FLAT SHEET
4' x 10' (1250 mm x 3050 mm)



NOBLE MATT COATED STEEL COIL
2 x 50 ft (625 mm x 15.24 mb)



RIDGE VENT ROLL
12 in x 16.5 ft (310 mm x 5 mb)



HIP AND RIDGE TILE TOP FOR ULTA
L=4 ft (1220 mm)



RIDGE END CAP RC-TOP



HIP AND RIDGE TILE FLAT FOR ULTA
L=4 ft (1220 mm)

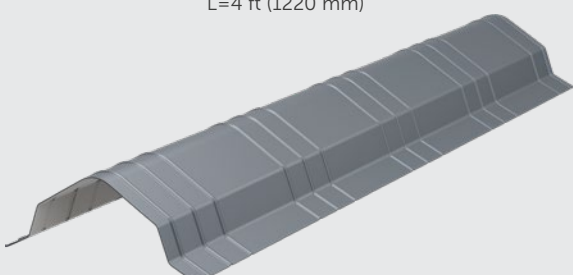

RIDGE END CAP RC-FLAT

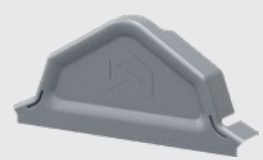

HIP CONE END CAP RC-FLAT



SEALING FOAM TAPE
0.4 in x 1.8 in x 10 ft 10 in (10 mm x 45 mm x 330 cm)



SNOW GUARD
9.25 in x 5.12 in x 3.15 in (235 mm x 130 mm x 80 mm)



HIP FLASHING HPL
L=45.08" (1145 mm)

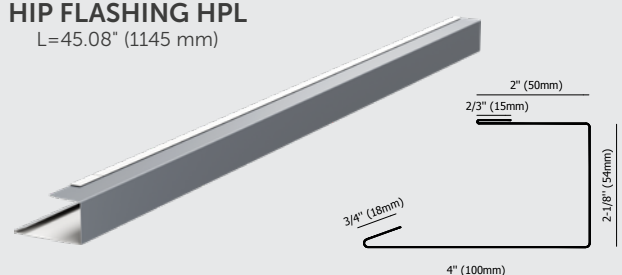

2" (50mm)
2/3" (15mm)
3/4" (18mm)
4" (100mm)
2-1/8" (54mm)

HIP FLASHING HPR
L=45.08" (1145 mm)

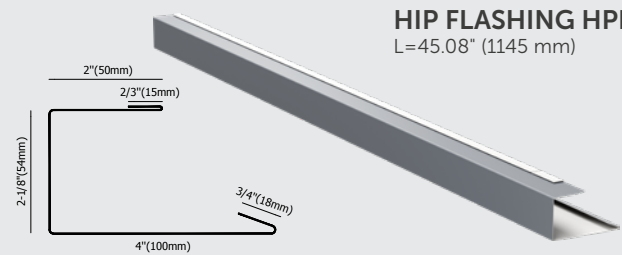

2" (50mm)
2/3" (15mm)
3/4" (18mm)
4" (100mm)
2-1/8" (54mm)

CHIMNEY VENT - UNINSULATED



UNIVERSAL

SELF-DRILLING FASTENERS
Available in Galvanized Steel or in Stainless Steel

Galvanized Steel

FSW METAL TO WOOD



1 3/8" (35 mm)
3/16" (5 mm)

FSM METAL TO METAL



3/4" (19 mm)
3/16" (5 mm)

Stainless Steel

FSW METAL TO WOOD

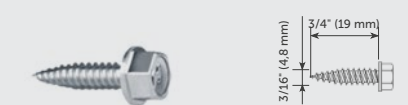

3/4" (19 mm)
3/16" (4.8 mm)

FSM METAL TO METAL



3/4" (19 mm)
3/16" (4.8 mm)

In business for more than 30 years

One of the largest companies of its kind in Europe. Privately owned with six automated mass production manufacturing facilities. 1300 employees. Successfully covering 35% of overall rooftops in Europe.

Worthouse products are in 41 countries around the world. Ongoing process for first manufacturing facility in United States. Northern America headquarters is located in Waynesboro GA.

Find out more at worthouse.com

Reaching above&beyond for you – approved for sales nationwide

- Miami Dade approval (Approval No. NoA 17/0221.05)
- Florida Product Approval FL21544/R1
- UL Classified evaluation UL ER39048/01, UL 1897, UL580
- TDI approval RC-563
- Constant evaluation of our system elements to ensure highest quality solution.

Worthouse Products are Full Roof System with Lifetime Warranty (30 years Coastal Warranty).

Engineered for difficult weather and environment conditions.

A roof that will last as long as its foundation

- Worthouse Modular Metal tile “warrantied duration” is achieved thanks to our source, multinational steel supplier ArcelorMittal providing the strongest raw material available.

For what matters most to you

- With the strongest warranty on the market, Worthouse is ensuring long term protection for your investments.
- Discounted insurance rates up to 25%.

The purchase of a lifetime

- Because your house is worth it.
- With up to a lifetime warrantied life cycle, divided by average costs for materials & installation Worthouse metal roofing achieves very low cost per square per year over its lifetime. Making it one of the most affordable roofing products on the market.



Eco friendly

- Products create less waste the market average of 10+%.
- Worthouse tiles can be 100% recyclable.
- Allows installation of solar panels.
- Little to no maintenance.

The beauty of seduction

- Worthouse products transform a everyday house to a home you love to see.
- With an elegant and innovative appealing design these products will improve greatly your house appearance.



Worthouse.®

Metal Roofing Manufacturing



Extreme weather protection against hailstorm, rain, snow, heat and wind



One pallet – one job



Lightweight and easy to handle



Pre-drilled holes enable self-calibration of roof



Easy and space efficient storage



Quick and efficient installation



Roof angle and partially installed roof corrections



Batch-to-batch color consistency guarantee



Less than 5% material waste



Complete set of accessories



High wind resistance



Fire protection – class A degree

Worthouse.® Inc.

321 Mills Rd.

Waynesboro

GA 30830

T: 847-621-2470 or 847-621-2951

worthouse@worthouse.com

worthouse.com

